

B1+ GYRATOR

... substituting a choke ...

By Barbara E. Gerhold, "TUBECLINIC"

There were so many inquiries about this little circuit that I decided to update this article. The main theme was how to calculate the virtual inductance of the gyrator as well as the several parts if other apps require other figures.

So I attached a math appendix at the back of the article, please see there.

I again wanted to thank Mr. van Hall for his splendid idea to feed the pre-stages (B1+) from the center point of the two serial caps of the B+ supply!

... but there was a little problem with increased hum at the output! Because my efficient horn speakers reflected this problem in a very audible way, I turned back to the connection from before, taking B1+ from the B+ supply via a heavy resistor chain.

Knowing that this special idea could be brought to a better result, I started to research, which design could give a better hum and noise figure. The found solution is again a gyrator, which might be usable also for other applications, so I started to write a new article about.

This "B1+ gyrator" circuit is intended to replace the choke 10H/25mA/EI55 from the circuit shown at my website.

The basic function of any gyrator is that an inverting, amplifying part (MOSFET, transistor) with a capacitance at the gate (base), acts like an inductance across drain/source (collector/emitter).

The value of inductance, which is achievable by this configuration, is much bigger than any "iron"-choke could become. So its hum and noise reduction is outstanding.

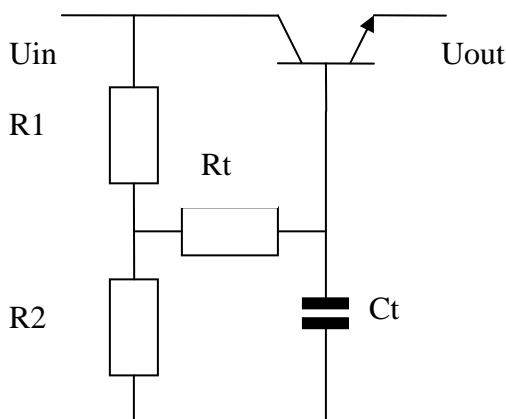

The critical values to calculate such a gyrator are R_t and C_t . These values define the final virtual inductance.

The ratio of $R1$ to $R2$ defines the voltage drop of the circuit. Please read the math appendix in behind of this article.

Have a look at the final schematic:

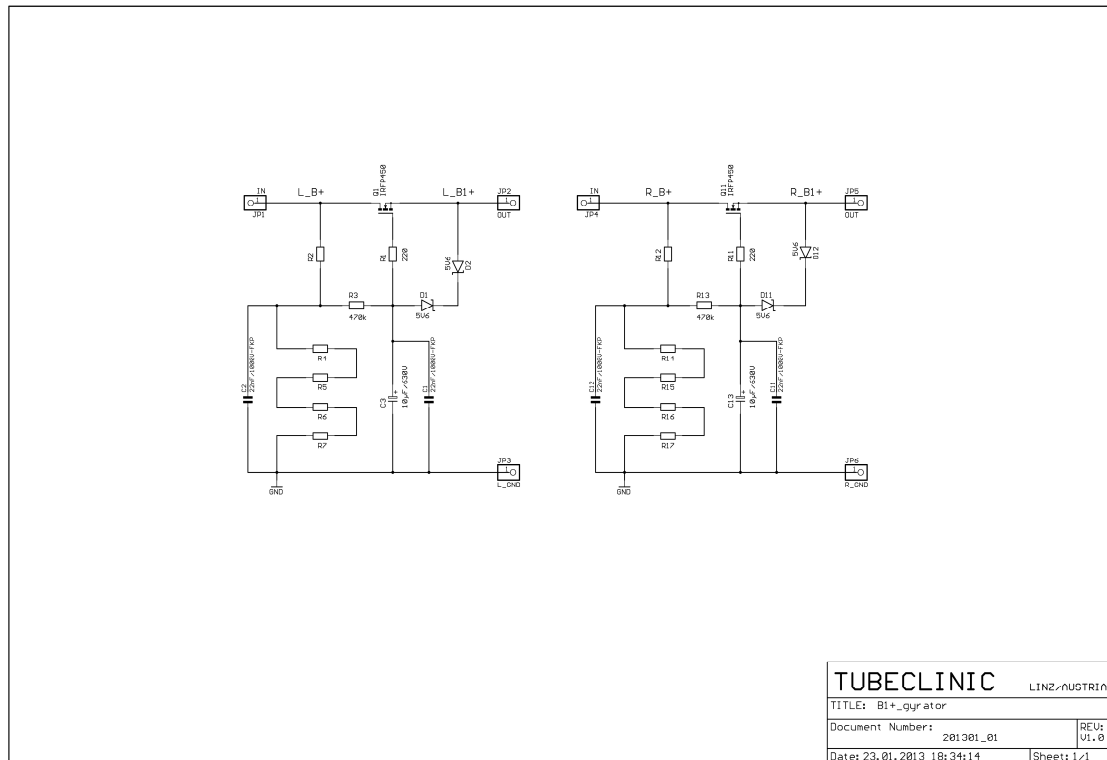

Function:

Because the above schematic consists of two identical circuits, I shall explain the circuitry only by the one for the left channel.

Substituting the choke, the terminals JP1 and JP2 are connected instead of the choke while JP3 is connected to GND.

The supply comes from the center point of the two caps in series and it measures half of the B+, in this case is half of the +930VDC -> +465VDC. The current across the resistor chain R2, R4, R5, R6, R7 (1W, ±1%, metal film) should be set to app. 1mA, so the total dissipation within will stay to less than ½W. Values can be found in a table in behind. Because this design was intended to be versatile, you can download a little EXCEL spreadsheet from my website, ready to calculate the needed values for your special application.

The voltage across R2 should be kept to at least 6 - 7VDC, so also the voltage across the power MOSFET Q1 will be app. 10VDC. The resistor R3 (0,5W, ±1%, metal film) charges the cap C3. It can be of large value, since the gate of the MOSFET is extremely high resistant. It resembles only a gate-charge of some nF. Resistor R1 (0,5W, ±1%, metal film) acts as a grid-stopper and shall only prevent oscillation.

Cap C2 is used to filter noise from the incoming supply voltage. It widely improves the noise figure. C1 in parallel to C3 serves the same reason. Both should be foil-type (best are MKP-X2 or FKP).

Power-up delay of this circuitry will be app. 4 seconds. This will also prevent bumps, coming from the charging of coupling caps.

The used MOSFET (IRFP450, datasheet at my website) will stand 500VDC across drain/source. If you wanted to use this circuit for a bigger voltage, you should consider a type showing bigger Uds. Furthermore, the MOSFET has to be mounted (insulated!) to a suitable heat sink (i.e. the amp-chassis itself). In the case of MA845, the power dissipation will be app. 0,2W during idling operation, but there will be some more during switch-on and if the circuit had to regulate, i.e. due to mains variations, it will be even more. If you increase the value of R2, the MOSFET will drop more voltage, so you could also adjust a personal B1+ within your amp. This again will lead to bigger dissipation and will increase heat. So be aware to apply a proper heat sink!

The math appendix for V 1.1:

It is not so easy to calculate the virtual inductance of this gyrator, because the used MOSFET shows no current amplification and its voltage amplification is close to 1 (a little less than 1 correctly) like any other source follower too. But that would be needed, if we wanted to calculate the inductance from common formula.

So we have to use another way: If the effect of a gyrator is equal to the effect of an iron choke, both values should be equal. Right? Let us calculate ...

The ripple filtering (smoothing) effect of an iron choke is given by its time constant "τ"

->The bigger the time constant, the bigger the filtering effect.

This time constant can be written as

$$\tau = \frac{L}{R_L} \quad \text{where L is the inductance and } R_L \text{ is the resulting resistance of the load}$$

Inserting L in [H] and R in [Ω] gives τ in [s].

Considering our MA845 B1+ supply, we have an output voltage of 430VDC and a load current of app. 18mA, therefore R_L is

$$R_L = \frac{430}{0,018} = 23,889k\Omega$$

So τ of the iron choke circuit is 10H / 23,889kΩ = 0,42ms.

The gyrator shows a time constant too. It is determined by R3 and C3.

This time constant can be written as

$$\tau = R_3 \cdot C_3 \quad \text{where the result is again [s], if we insert R in [Ω] and C in [F].}$$

Setting both τ to be equal, we can write

$$R_3 \cdot C_3 = \frac{L}{R_L} \quad \Rightarrow \quad L = R_3 \cdot C_3 \cdot R_L \quad \Rightarrow \quad L_{virt} = \frac{R_3 \cdot C_3 \cdot U_{out}}{I_L} \quad [1]$$

Calculating the virtual inductance L_{virt} of the B1+ gyrator circuit from equation [1] gives

$$L_{virt} = \frac{470k * 10\mu F * 430V}{18mA} = 112278 [H]$$

You see, that you can achieve thousands of virtual Henries by this means.

Like an iron choke, the gyrator shows a drop in DC voltage too. With the iron choke, this DC drop comes due the R_{dc} of the copper winding. In our case this drop is 10,7VDC (pls. see EXCEL spreadsheet). So we calculate $10,7V / 18mA = 594\Omega$.

This value can be adapted by simply changing the value of R2, which makes it possible to customize the output voltage to the needed value.

Since a gyrator does not store energy like an iron choke, it is essentially necessary to choose a DC voltage-drop bigger than the peak-to-peak ripple of the input voltage!

As you already know – all information about the printable, full-size schematic and the PCB is again situated in a binder enclosed to this website (<http://www.tubeclinic.com>).

If you have any further question, you can contact me via support@tubeclinic.com.